

# OPERATOR'S MANUAL

**Caliber .223  
(5.56mm)**



**HK<sup>®</sup>**  
**HECKLER & KOCH**

# SL8-1 & SL8-6

**CAUTION: Read the safety notes before handling the SL8-1 & SL8-6 Rifle!**

# SL8-1 & SL8-6

## Sporting Rifle

### Operators Manual



*All photographs in this manual are of the SL8-1*



**HECKLER & KOCH**

© Heckler & Koch, Inc., 11/99 (revised 10/2006) (5/2026)

All rights reserved

Heckler & Koch

5675 Transport Blvd.

Columbus, GA USA

Telephone (706) 568-1906

Specifications and models subject to change without notice.

# **TABLE OF CONTENTS**

---

Safety Notes on the Use of the SL8-1 & SL8-6 rifle .....	4
General .....	6
Assembly Groups .....	8
Description of Assembly Groups.....	9
Group 1 Receiver with barrel, buttstock and attaching parts .....	9
Group 2 Bolt Assembly .....	10
Group 3 Buttstock Assembly (with trigger & safety mechanism) ..	12
Group 4 Handguard .....	14
Group 5 Magazine .....	14
Handling and Operation .....	15
Operation of Parts .....	20
Disassembly of the SL8-1 & SL8-6 .....	22
Assembly of the SL8-1 & SL8-6.....	26
Disassembly and Assembly of the magazine.....	28
Adjustment of the Stock and Cheekpiece .....	29
Adjustment of the Sights .....	31
Optical Sights .....	32

## ***TABLE OF CONTENTS***

---

Maintenance and Service .....	33
Troubleshooting Guide.....	35
Parts & Exploded Diagram.....	38
Specifications .....	40
Firearm Service Record .....	41

# **SAFETY NOTES**

---

## **Safety Notes on the Use of the HK SL8-1 & SL8-6**

**Clear the rifle! Before handling the firearm, “clear it!” Do so by:**

1. Make sure fingers are outside of the trigger guard and the firearm is pointed in a safe direction at all times!
2. **ON SAFE** – Rotate the safety/selector lever to the “Safe” position (the white “S” adjacent to the safety/selector lever)
3. **REMOVE MAGAZINE** – Depress the magazine paddle release lever and remove the magazine from the magazine well.
4. **COCKING LEVER** – Rotate the ejection port towards the ground and fold out and pull the cocking lever rearward one or more times to insure the chamber is empty. Watch for a live round or empty case to be ejected. Move the cocking lever upward slightly and lock it into the indent in the cocking lever housing to lock the bolt open.
5. **BOLT CATCH** – While holding the cocking lever fully rearward use the trigger finger to press upwards on the bolt catch button located in the front top corner of the trigger guard to lock the bolt rearward.
6. **INSPECT CHAMBER** – Inspect the chamber for the presence of a live round or empty case.  
Visually – View the chamber through the open ejection port.  
Physically – Insert index finger through magazine well or ejection port and feel for the presence of a round or cartridge case in the chamber.
7. Remove any live rounds or empty cases from the chamber or from within the firearm or magazine before handling the firearm further.

**The HK SL8-1 & SL8-6 is now considered “Clear.”**

---

### **WARNINGS**

- **Carefully read this operators manual before handling the rifle.**
- **Only use the rifle after you have fully reviewed and understand these instructions.**
- **Observe all notes on handling and operation. Failure to do so may result in injury or death of the operator or bystanders.**
- **Do not use the rifle if you have previously ingested alcohol or drugs.**
- **When passing the rifle between persons, the firearm must be clear and the bolt should be open.**
- **Always treat the rifle as if it were loaded and ready to fire.**
- **Never point the rifle at anyone during handling.**

- Always point the rifle in a safe direction.
  - Before handling and before cleaning check the rifle to ensure that:
    - The bolt is locked to the rear
    - The rifle is unloaded (cartridge chamber empty)
    - The barrel is free of obstructions
    - The magazine is empty.
  - Keep your finger off the trigger when loading, unloading or otherwise handling the rifle. Always place the trigger finger outside of the trigger guard.
  - Place your finger on the trigger only when your sights are aimed at the target.
  - Never use force when handling, disassembling, cleaning and assembling the rifle.
  - Disassemble the rifle only as far as described in this manual.
  - Always wear eye and hearing protection when using the rifle.
  - Take into account the fact that bystanders are also endangered. Ensure bystanders are also wearing ear and eye protection.
  - Only use factory-loaded and undamaged cartridges of the correct caliber.
  - Always mind that the muzzle area is free of obstacles during firing.
  - Store firearms and ammunition in separate places.
  - Discharging firearms in poorly ventilated areas, cleaning firearms, or handling ammunition may result in exposure to lead, a substance known to be associated with birth defects, reproductive harm, and other serious injuries. Have adequate ventilation at all times. Wash hands thoroughly after exposure.
  - HKI does not assume any liability for events due to disregarding this manual, improper handling, negligence, improper treatment, use of improper or reloaded ammunition, unauthorized exchange of parts or manipulations of the rifle.
  - Remember, firearms safety begins with you. Read this operators manual and be familiar with the safe handling of this firearm before using it. Store all firearms in a safe and secure location. Keep firearms away from children. Always be a safe shooter. Keep this manual with the rifle.
-

## **GENERAL**

---

The HK SL8-1 & SL8-6 semiautomatic rifle is a caliber .223 Remington civilian sporting arm based on the G36 rifle currently used by the German Army.

The SL8-1 & SL8-6 rifles are gas operated with a rotating bolt head. Its receiver, pistol grip, buttstock, and handguard are all made of a high-strength polymer material, resulting in a tough and lightweight rifle.

A mechanical sight is mounted on the Picatinny long rail found on the top of the upper receiver. This sighting system can be easily replaced by other sighting systems, including optical scopes.

A movable buttplate and cheekpiece are other features that can be adjusted to the individual needs of the user.

The heavy barrel and the chamber are cold hammer forged and hard chrome plated for durability and accuracy. The barrel is fastened and centered to the receiver by means of a hex nut.

A cocking lever on the front end of the bolt head carrier can be swiveled to the left and to the right for actuation by both left and right handed users.

The magazine holds 10 rounds.

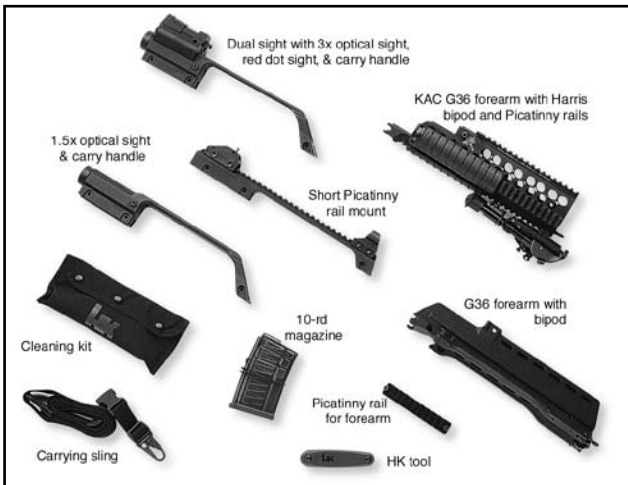
A bolt catch locks the bolt rearward (open) when the last round is fired or an empty magazine is inserted and the bolt is retracted.



*Figure 1 SL8-1 & SL8-6 with mechanical sights (left side view)*



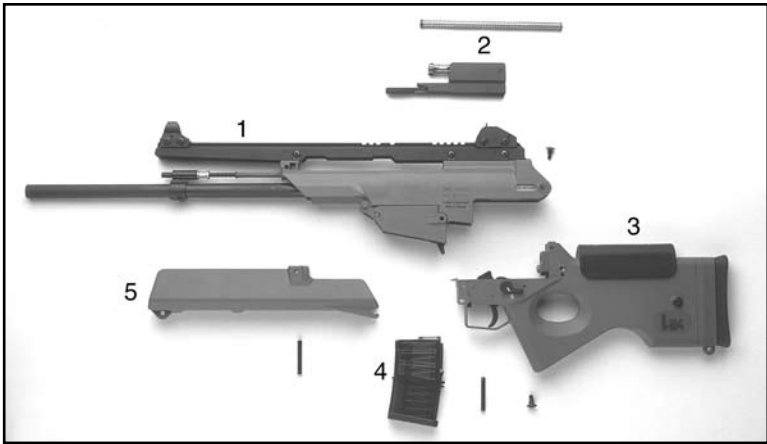
*Figure 2 SL8-1 & SL8-6 with mechanical sights (right side view)*



*Figure 3 SL8-1 & SL8-6 Accessories*

## ***ASSEMBLY GROUPS***

---



*Figure 4 SL8-1 & SL8-6 Assembly groups*

1. Receiver with barrel, gas system, magazine well, mounting rail with mechanical sights
2. Bolt assembly with recoil spring assembly
3. Buttstock assembly complete
4. Magazine
5. Handguard

## ***DESCRIPTION OF ASSEMBLY GROUPS***

### **Group 1 - Receiver with barrel, buttstock and attaching parts**

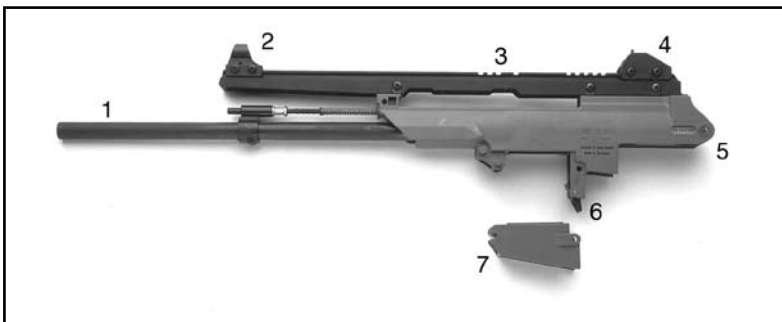
The receiver is made of high-strength fiber-reinforced plastic. It houses all the other assembly groups. Inside the receiver there are guideways for the bolt as well as contact surfaces for the pistol grip, the buttstock and the magazine well. The barrel is fastened and centered to the receiver by means of a nut.

**CAUTION: The barrel nut should not be removed by the operator. Only HK certified armorers should attempt to remove the barrel.**

On the right side of the receiver is an ejection port with an integral cartridge case deflector. The cartridge case deflector directs the ejected cases (at an angle of approximately 45° to the muzzle) away from the shooter.

The handguard and magazine well are fitted to the bottom of the receiver by means of removable locking pins.

The buttstock with trigger mechanism is fastened to the receiver by means of two hex head screws. To fasten and unfasten them use the HK special tool provided with the rifle.



*Figure 5*

*Receiver with barrel, gas system, mounting rail with mechanical sights*

1. Barrel
2. Front sight
3. Mounting rail
4. Rear sight
5. Receiver
6. Magazine catch
7. Magazine well

## **DESCRIPTION OF ASSEMBLY GROUPS**

---

### **Gas block**

The gas block is fastened with a cross pin to the barrel; do no attempt to remove it. After the bullet has passed the gas vent hole in the barrel, a portion of the propellant gases are guided into the gas cylinder within the gas block and actuate the gas piston.

The gas piston drives the bolt assembly rearward via the push rod. The return spring on the push rod returns the rod to its starting position.



*Figure 6 Gas system*

### **Magazine well**

The front of the magazine well engages into two support studs on the receiver. For fastening, the magazine well is swiveled upward. A locking pin fastens both the pistol grip and the magazine well to the receiver. When the locking pin is removed the magazine well is retained by the magazine catch.

### **Group 2 - Bolt assembly**

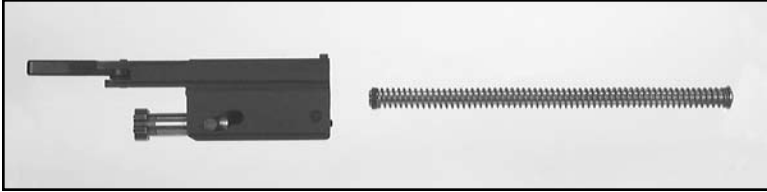
The bolt assembly with the rotary bolt head is guided into the receiver by metal guide rails molded into the polymer receiver. The bolt assembly is driven rearward by the gas piston then driven forward by the recoil spring. The bolt assembly serves multiple functions including; feeding the cartridges, locking of the chamber, cartridge ignition, case extraction and ejection, as well as cocking of the hammer.

The bolt head is retained in the bolt head carrier by the cam pin which also controls its rotary movement. Locking lugs are machined onto the front of the bolt head. The spring-loaded extractor is located in a gap between the locking lugs. Adjacent to the extractor is a spring-loaded ejector.

## ***DESCRIPTION OF ASSEMBLY GROUPS***

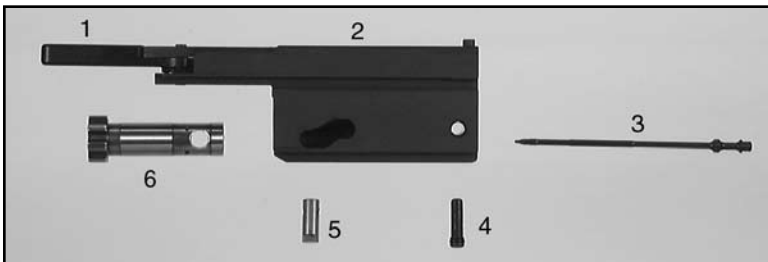
The firing pin is retained by the firing pin retaining pin.

A cocking lever on the front end of the bolt head carrier can be swiveled to the left and to the right for actuation by both left and right handed users. It can also be locked in a 90° position to the left and right for use as a forward assist.



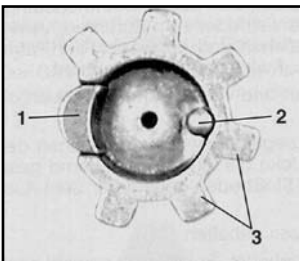
*Figure 7 Bolt assembly with recoil spring assembly*

The recoil spring guide rod with the recoil spring is a separate unit and fits into the bolt head carrier. Rearward movement of the bolt assembly is stopped by a buffer in the buttstock.



*Figure 8 Bolt assembly*

- |                      |                  |
|----------------------|------------------|
| 1. Cocking lever     | 4. Retaining pin |
| 2. Bolt head carrier | 5. Cam pin       |
| 3. Firing pin        | 6. Bolt head     |



- |                           |
|---------------------------|
| 1. Extractor              |
| 2. Ejector                |
| 3. Locking lugs (6 total) |

*Figure 9 Bolt head*

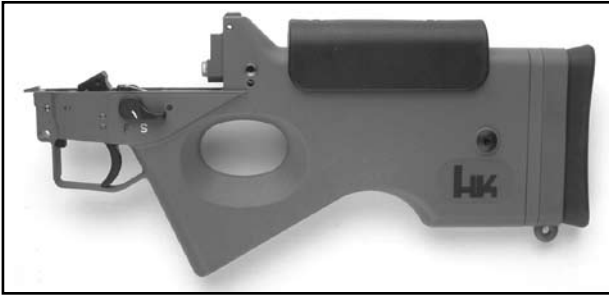
## **DESCRIPTION OF ASSEMBLY GROUPS**

### **Group 3 - Buttstock Assembly, Complete**

The buttstock is fixed to the receiver by the means of two hex head screws which can be opened and closed with the HK Tool. The buttstock includes an integral rear sling attachment point.

The buttplate and cheekpiece can be adjusted to the individual requirement of the user by the means of spacers.

The trigger and safety/selector lever is located at the front end of the buttstock.



*Figure 10 Buttstock assembly complete*



*Figure 11  
Cheekpiece*



*Figure 12  
Buttplate with  
interchangeable spacers*

## ***DESCRIPTION OF ASSEMBLY GROUPS***

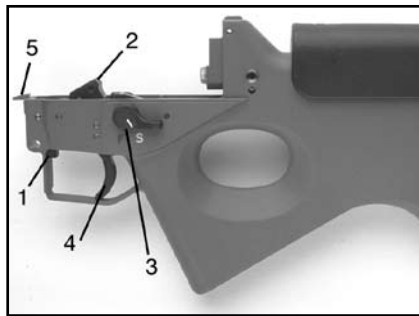
### **Trigger and Safety Mechanism**

The trigger and safety are integrated into the buttstock assembly.

At the front of the trigger guard there is a bolt catch button which is used to hold the bolt open on an empty magazine or when fired “dry.” There are safety selector levers on both sides of the grip. The safety/selector levers can be placed in two positions:

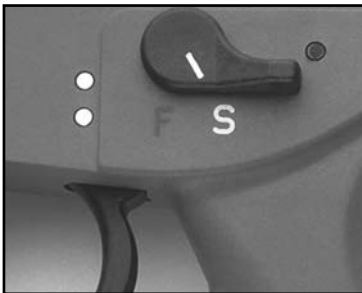
“S” = Safe (white index line on the safety/selector lever pointing to the white “S”)

“F” = Fire (semi-automatic white index line on the safety/selector lever pointing to the red “F”)

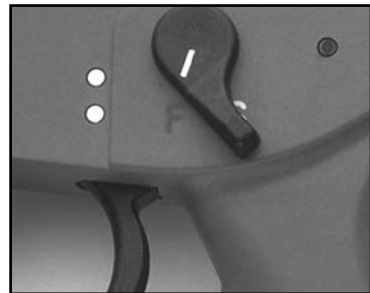


*Figure 13 Trigger and safety mechanism*

1. Bolt catch button
2. Hammer
3. Safety/selector lever
4. Trigger
5. Bolt catch



*Figure 14A Safety/selector position*



*Figure 14B Safety/selector position*

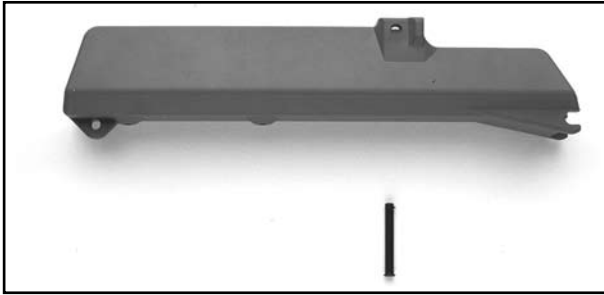
*“Safe”*

*“Fire” (semi-automatic)*

## **DESCRIPTION OF ASSEMBLY GROUPS**

### **Group 4 - Handguard**

The detachable handguard encloses the barrel and the gas system. The handguard is positioned at the receiver by means of two support studs and is fastened there by means of a removable locking pin. The handguard incorporates a sling attachment point and two threaded hard points for accessory attachment.



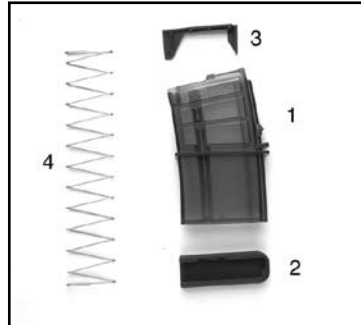
*Figure 15 Handguard*

### **Group 5 - Magazine**

The detachable box-type magazine holds a maximum of 10 rounds. The magazine housing consists of impact-resistant transparent plastic which allows the user to visually check the contents of the magazine from the outside.



*Figure 16 Magazine*



*Figure 17 Magazine disassembled*

The magazine consists of:

1. Magazine housing
2. Magazine floorplate
3. Follower
4. Follower spring

### **Ammunition and Accuracy**

By using ammunition with match bullets or other match grade ammunition the HK SL8-1 & SL8-6 will achieve the best level of accuracy.

**NOTE: Use only .223 Remington or 5.56 x 45mm NATO ammunition in the SL8-1 & SL8-6 rifle. Damage caused by the use of improperly assembled or remanufactured ammunition in the SL8-1 & SL8-6 may void the HK Warranty. Do not use ammunition assembled with corrosive components (primers, propellants, etc.).**

### **Mounting Rail**

The rail with mechanical iron sights is not designed to be a carrying handle.

**CAUTION: Except for loading and unloading the rifle there should be no finger placed between the rail and the receiver.**

**NOTE: If the bolt is locked to the rear by the bolt catch and the magazine is removed, a hard knock on the buttstock, like slamming the gun to the ground will release the bolt. However, to avoid damage to the rifle, the bolt should be pulled fully rearward and released.**

### **Safe handling**

Compared to the military issue G36 assault rifle, the trigger pull of the SL8-1 & SL8-6 is significantly reduced. If the weapon is loaded, avoid rough handling and drops.

Because of the absence of a firing pin spring, a slight mark on the primer can be seen after chambering a round. This has no influence on the handling safety of the rifle; without pulling the trigger the gun will not fire. Please avoid chambering the same round several times in sequence as the bullet can be worked loose from the cartridge.

Cartridges assembled with projectile weights from 50-70 grains are recommended for use with the SL8-1 & SL8-6 rifle.

## ***HANDLING AND OPERATION***

---

### **Loading of the magazine**

1. Hold the magazine with one hand. Place a cartridge with the other hand slightly forward of the the magazine lips and push back and downward until the cartridge is held underneath the lips.
2. Repeat this operation until the magazine is fully loaded and the desired 10 rounds are inside the magazine.



*Figure 18 Loading of the magazine*

### **Unloading the magazine**

Hold the magazine with one hand. Push the cartridges forward out of the magazine with the thumb of the other hand. Do not allow the cartridges to drop on a hard surface or they may become damaged.

### **Loading the Rifle**

Method 1:       No magazine in the weapon  
                  The bolt is in its forward (locked) position

1. Set the safety/selector lever on “Safe.”
2. Swivel the cocking lever to the left or to the right, pull it all the way to the rear (Figure 20) and hold it.



*Figure 20 Operating the cocking lever*

3. Push the bolt catch button upward to lock the bolt open (rearward, see Figure 21)



*Figure 21 Activate bolt catch, push upwards*

4. Insert a loaded magazine into the magazine well until the magazine catch clearly engages. Swivel the cocking lever out, pull it all the way to the rear and release it.

The weapon is now loaded and set on “Safe.”

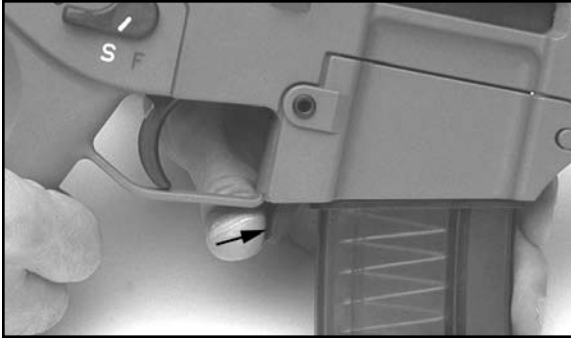
## **HANDLING AND OPERATION**

---

### **Reloading the Rifle**

Method 2:       The magazine in the weapon is empty.  
                  The bolt has been held in its rear position by the bolt catch.

1. Set the safety/fire selector lever at "Safe."
2. Push the magazine catch forward with the thumb and remove the empty magazine (see Figure 22 below).



*Figure 22 Release magazine (push forward)*

3. Insert a loaded magazine into the magazine well until the magazine clearly engages. Tug on the magazine to ensure it is securely engaged.
4. Swivel the cocking lever out, pull it all the way to the rear and release (see Figure 20).

The weapon is now loaded and set on "Safe."

### **Forward assist**

If the exterior of the rifle is very dirty (sand, mud etc.) the cocking lever can also be used as a forward assist.

To use the cocking lever as a forward assist

1. Swivel out the cocking lever and push it inward against the bolt head carrier (the cocking lever remains in its swiveled position).
2. Push the bolt head carrier with the cocking lever forward until it fully locks closed.
3. Pull the cocking lever outward and let it swivel to its initial position (parallel with the bolt head carrier).



*Figure 23 Cocking lever shown in its "forward assist" position*

Low-noise loading using the forward assist

1. After the magazine has been inserted, swivel out the cocking lever and push it inward against the bolt head carrier until it engages (see Figure 23).
2. Pull the cocking lever slightly to the rear and guide it forward.
3. Push the cocking lever forward until the bolt locks.
4. Pull the cocking lever outward and let it swivel to its initial position (parallel with the bolt head carrier).

The rifle is now loaded and set at "Safe."

**WARNING: Never fire the SL8-1 & SL8-6 with cocking handle locked in the 90° forward assist position or injury may occur.**

## OPERATION OF PARTS

### **Bolt Locked**

The barrel is tightly screwed to the barrel extension by means of a nut. The bolt head carrier houses the bolt head which can move along its longitudinal axis inside the bolt head carrier. Additional to its longitudinal movement the bolt head can also rotate around its longitudinal axis.

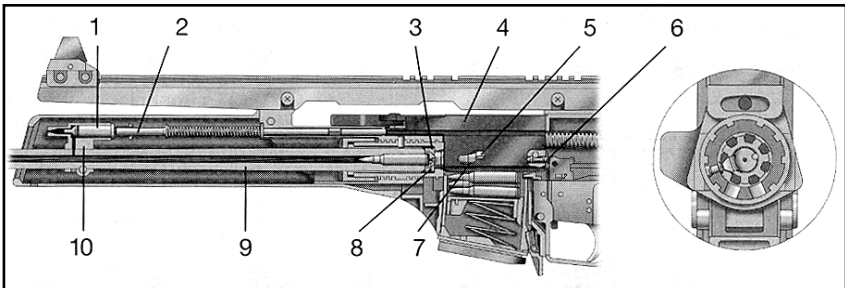
In the locked condition the bolt head is in the foremost position. The bolt head in the bolt head carrier is turned in such a way that the locking recesses of the bolt head engage the corresponding locking lugs of the barrel extension.

The SL8-1 & SL8-6 is now loaded and safety selector lever set to fire.

Pulling the trigger releases the hammer which hits the firing pin and ignites the cartridge.

The propellant gases accelerate the bullet. As soon as the bullet has passed the gas vent hole, a portion of the gases enter the gas block and the gas cylinder.

These gases push the bolt head carrier via the gas piston and the push rod to the rear. The camming slot in the bolt head carrier causes the cam pin to pivot downward, which in turn rotates the bolt head and unlocks it.



*Figure 24 Bolt in locked position*

- |                      |                     |
|----------------------|---------------------|
| 1. Gas piston        | 6. Firing pin       |
| 2. Push rod          | 7. Camming slot     |
| 3. Bolt head         | 8. Barrel extension |
| 4. Bolt head carrier | 9. Barrel           |
| 5. Cam pin           | 10. Gas Block       |

### Bolt Unlocked

The locking lugs disengage. The bolt head disengages (unlocks) from the barrel extension. Bolt head carrier and bolt head move to the rear. The extractor in the bolt head extracts the cartridge case by its rim from the chamber. When the bolt assembly passes the ejection port, the spring-loaded ejector ejects the cartridge case through the open ejection port forward and to the right.

The rearward movement of the bolt assembly compresses the recoil spring and cocks the hammer.

If the magazine is empty, the follower lifts the bolt catch upward which holds the bolt rearward. If a round is present in the magazine, the bolt assembly, driven by the recoil spring moves forward and pushes the uppermost cartridge out of the magazine into the chamber.

The bolt head contacts and stops at the rear face of the barrel and the bolt head carrier continues its forward movement which rotates the bolt head via the cam pin and the camming slot into the locked position.

The firing pin tip can only protrude through the bolt face and hit the primer when the bolt is fully locked. The weapon is now ready to fire again.

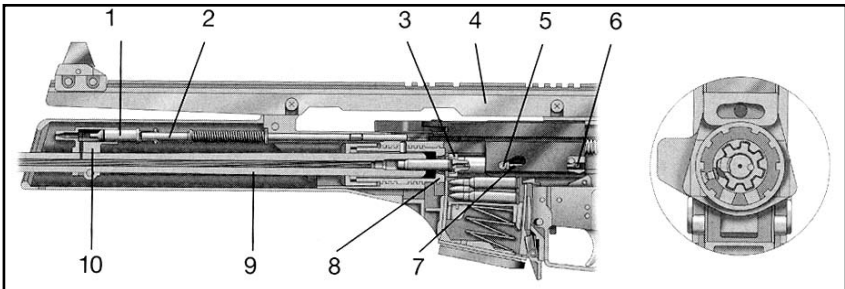


Figure 25 Bolt in the unlocked position

- |                      |                     |
|----------------------|---------------------|
| 1. Gas piston        | 6. Firing pin       |
| 2. Push rod          | 7. Camming slot     |
| 3. Bolt head         | 8. Barrel extension |
| 4. Bolt head carrier | 9. Barrel           |
| 5. Cam pin           | 10. Gas block       |

## **DISASSEMBLY OF THE SL8-1 & SL8-6**

**Clear the rifle! Before handling the firearm, “clear it!” Do so by:**

1. Make sure fingers are outside of the trigger guard and the firearm is pointed in a safe direction at all times!
2. ON SAFE – Rotate the safety/selector lever to the “Safe” position (the white “S” adjacent to the safety/selector lever)
3. REMOVE MAGAZINE – Depress the magazine paddle release lever and remove the magazine from the magazine well.
4. COCKING LEVER – Rotate the ejection port toward the ground and fold out and pull the cocking lever rearward one or more times to ensure the chamber is empty. Watch for a live round or empty case to be ejected.
5. BOLT CATCH – While holding the cocking lever fully rearward use the trigger finger to press upward on the bolt catch button located in the front top corner of the trigger guard to lock the bolt rearward.
6. INSPECT CHAMBER – Inspect the chamber for the presence of a live round or empty case.  
Visually – View the chamber through the open ejection port.  
Physically – Insert index finger through magazine well or ejection port and feel for the presence of a round or cartridge case in the chamber.
7. Remove any live rounds or empty cases from the chamber or from within the firearm or magazine before handling the firearm further.

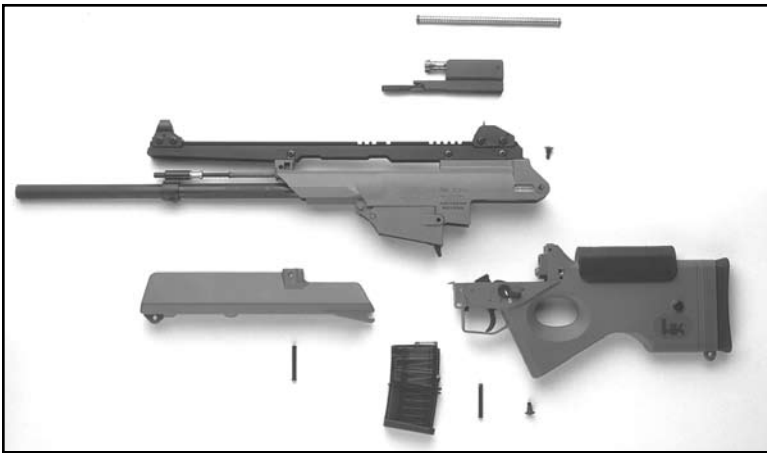
The HK SL8-1 & SL8-6 is now considered “Clear.” Once clear, let the bolt move forwards.

**NOTE: The SL8-1 & SL8-6 is easily disassembled and reassembled with the HK Tool. Do not use force in any of the disassembly procedures. Disassembly beyond the procedures outlined in this manual is not recommended and may void the HK Warranty. Disassembly beyond the operators level described here may be carried out by qualified maintenance personnel only. Contact HK for more information.**

## ***DISASSEMBLY OF THE SL8-1 & SL8-6***

### **Stripping into assembly groups**

1. Use the 5 mm Allen wrench of the HK tool and remove the hex headed Allen screws located on the left and right sides of at the rear end of the receiver
2. Remove the locking pin above the front end of the trigger guard.
3. Pull the buttstock with the trigger back out of the receiver.
4. Pull the cocking lever to the rear and remove the bolt.
5. Pull out the locking pin at the handguard and remove the handguard to the front.
6. Push the magazine catch, swivel the magazine well downward and detach.



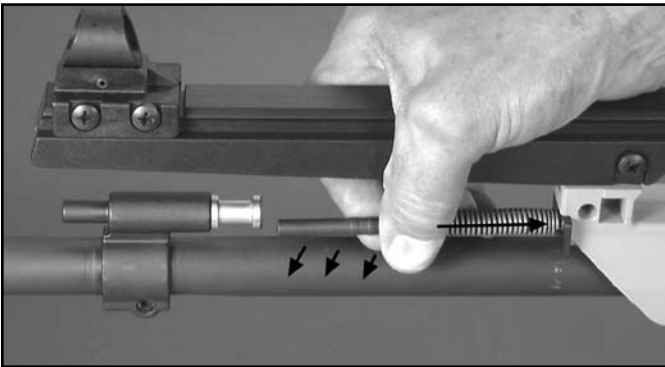
*Figure 26 Stripping SL8-1 & SL8-6 into assembly groups*

## **DISASSEMBLY OF THE SL8-1 & SL8-6**

### **Disassembly of the push rod and the gas piston**

**CAUTION: The push rod is under considerable spring tension. Use caution when installing and removing it. To avoid injury to yourself and others, never point the compressed push rod in an unsafe direction in the event it is inadvertently released under pressure.**

1. Push the push rod to the rear against spring pressure and remove it from the gas piston.
2. Swivel the push rod to the side and remove it to the front.
3. Remove the gas piston to the rear.



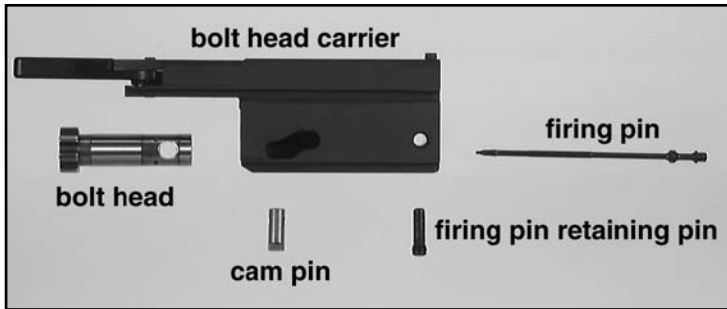
*Figure 27 Removing push rod*



*Figure 28 Removing the gas piston*

### **Disassembly of the bolt assembly**

1. Push the firing pin retaining pin to the left (e.g. with gas piston) and detach.
2. Remove the firing pin to the rear.
3. Take out the cam pin to the left.
4. Detach the bolt head to the front.



*Figure 29 Bolt head disassembled*

## **ASSEMBLY OF THE SL8-1 & SL8-6**

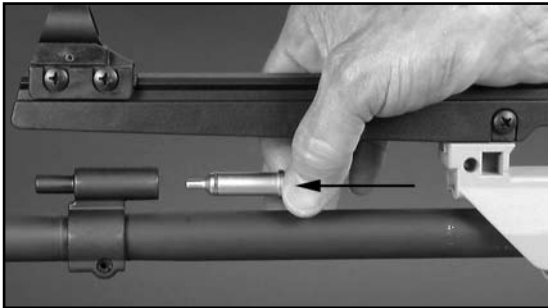
### **Assembly of the bolt**

1. Slide the bolt head with the extractor on the right, as viewed from the rear, into the bolt head carrier.
2. Insert the cam pin from the left into the bolt head carrier and the bolt head; mind that the flat surfaces on the cam pin and the hole for the firing pin are parallel to the bore.
3. Introduce the firing pin from the rear into the bolt head carrier and the bolt head.
4. Insert the firing pin retaining pin from the left side into the bolt head carrier to secure the firing pin and cam pin in place.
5. Determine that all parts are assembled in proper sequence and complete and that the bolt head and cam pin move freely within the bolt head carrier.

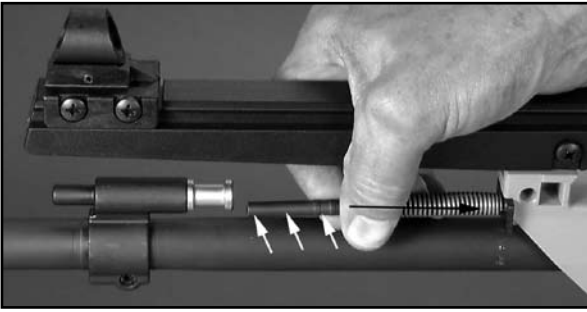
### **Assembly of the gas system**

1. Insert the gas piston into the gas block.
2. Introduce the push rod into the front part of the receiver, push it against the spring pressure into the receiver and let it slide into the gas piston.

**CAUTION: The push rod is under considerable spring tension. Use caution when installing and removing it. To avoid injury to yourself and others, never point the compressed push rod in an unsafe direction in the event it is inadvertently released under pressure.**



*Figure 30 Installing the gas piston*



*Figure 31 Installing the push rod*

### **Assembly of the SL8-1 & SL8-6**

1. Slide the handguard from the front over the barrel and the receiver. Align notches onto studs.
2. Fasten the handguard with the locking pin.
3. Place the front of the magazine well onto the bearing studs, swivel the rear of the magazine well upward all the way until it engages the magazine catch.
4. Insert the bolt assembly from the rear into the receiver together with the recoil spring.
5. Push the buttstock assembly with trigger mechanism (hammer is back, in the cocked position) from the rear into the receiver and insert the locking pin above the trigger guard.
6. Fasten the buttstock to the receiver by the means of the Allen screws with the HK Tool (do not use excess force to tighten them down).
7. Set the SL8-1 & SL8-6 safety/selector on "Safe!"
8. Insert the magazine.

## **DISASSEMBLY & ASSEMBLY OF THE MAGAZINE**

### **Disassembly of the magazine**

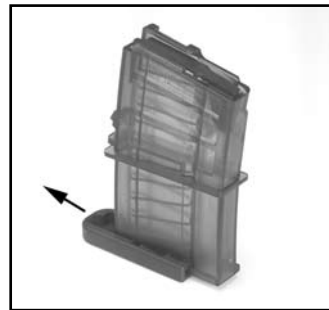
1. Press the bottom of the right sidewall of the magazine inward until the front catch is disengaged.
2. Push the magazine floorplate to the rear.
3. Press the bottom of the right sidewall inward until the rear catch is disengaged.
4. Remove the floorplate to the rear.

**WARNING: The magazine spring is under pressure! Remove the magazine spring and the follower from the bottom of the magazine while holding the magazine with the bottom pointed downward.**



*Figure 32*

*Press magazine sidewalls*



*Figure 33*

*Remove floorplate*



*Figure 34 Magazine disassembled*

### **Assembly of the magazine**

1. Insert the follower and the magazine spring from the bottom into the magazine housing.
2. Slide the magazine floorplate from the rear onto the magazine housing.
3. Push the magazine floorplate all the way over the two catches onto the magazine housing.

## ***ADJUSTMENT OF THE STOCK & CHEEKPIECE***

### **Buttstock adjustments**

The cheekpiece and buttplate can be adjusted by means of removable spacers to the user's preference.

### **Adjustment of buttstock length**

1. Use the 5mm Allen wrench of the HK Tool to remove the hex head screw on the left and right side of the rear of the buttstock assembly.
2. Pull buttplate with spacer back out of the buttstock.



*Figure 35  
Remove buttplate with spacer*

3. To adjust the buttstock length to your requirement you can use up to five spacers. Each spacer is 10 mm (approximately 1/2 inch wide). Maximum adjustment is 2 inches.
4. Push back buttplate with the required number of spacers into the buttstock and fasten the two hex head screws with the HK Allen wrench.

---

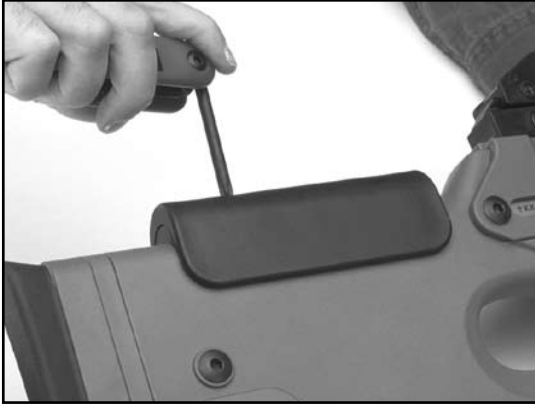
**NOTE: The buttstock can be set at any length without the use of optional spacers by using the two hex head screws to secure the buttplate in position.**

---

## **ADJUSTMENT OF THE STOCK & CHEEKPIECE**

### **Adjustment of the cheekpiece**

1. Use the Phillips screwdriver of the HK Tool to remove the two Phillips screws from the cheekpiece.
2. You can use the cheekpiece alone or with up to two spacers.
3. Tighten the cheekpiece with or without spacers to the buttstock by using the Phillips screwdriver.



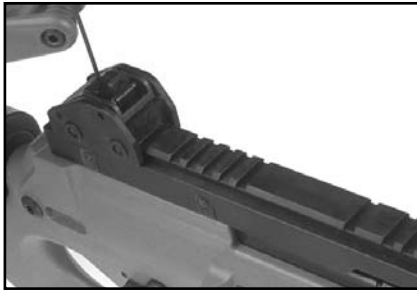
*Figure 36 Adjustment of cheekpiece*

### **Sight Adjustments**

If the point of impact of several shots does not coincide with where you aimed, a sight adjustment is necessary. The SL8-1 & SL8-6 is zeroed at 100 meters point of aim point of impact using the 100 meter rear sight aperture. For zeroing, select the 100 meter rear sight aperture. For zeroing, select the 100 meter rear sight aperture.

### **Elevation Adjustment**

- If shots are high, the elevation adjustment screw should be turned clockwise with the 2.5mm Allen wrench of the HK Tool.
- If shots are low, turn the screw counterclockwise.
- A full turn of the adjustment screw will move the point of impact 11 cm or 4-1/2 inches up or down at a distance of 100 meters.



*Figure 37 Elevation Adjustment*

### **Windage Adjustment**

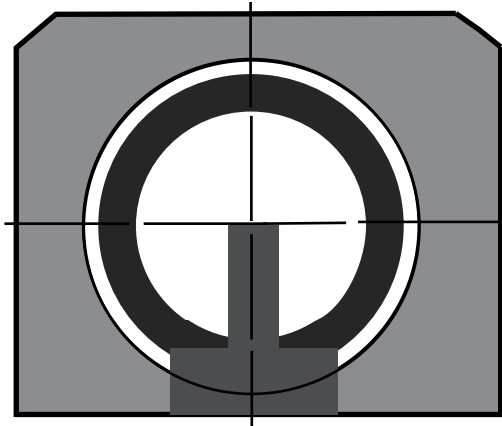
- If shots are right of the point of aim, use the 2mm Allen wrench and turn the windage adjustment screw clockwise.
- If shots are to the left of the point of aim, turn the windage adjustment screw counterclockwise.
- One click of the side adjustment screw moves the point of impact 3.3 centimeters (or 1-1/4 inches) left or right.



*Figure 38 Windage Adjustment*

## ***ADJUSTMENT OF THE SIGHTS***

---



*Figure 39 Proper sight alignment for the SL8-1*

**NOTE: When engaging targets that are 300 meters away, flip the 300 meter rear sight aperture into position to account for the drop in the trajectory of the projectile.**

## **Cleaning and Preservation**

To clean and maintain the SL8-1 & SL8-6 self-loading rifle you may use:

- The HK cleaning kit caliber .223/5.56 mm
- Off the shelf cleaning kits caliber .223/5.56 mm
- Cotton patches and soft tissue
- Chloride and acid-free cleaning and preservation fluids

**NOTE: Do not use steel tools or brushes to clean your SL8-1 & SL8-6 or synthetic materials like nylon when the weapon is hot. Keep cleaning solvents away from the painted surfaces of the SL8-1 & SL8-6, to include the safety/selector and the “Safe” and “Fire” symbols. Proper cleaning and maintenance of your SL8-1 & SL8-6 will extend the life of the rifle.**

### **Normal Cleaning:**

You should do this after every firing of the gun:

1. Remove magazine
2. Set the SL8-1 or SL8-6 safety/selector lever to “Safe” and ensure the chamber is clear
3. Use a nylon brush and soft tissue to clean the outside
4. Lock the bolt to the rear and run a bronze bristle bore brush soaked with solvent several times through the barrel; follow with clean patches
5. Apply a light coat of oil to the barrel
6. Following cleaning, check function of all parts
7. Set the SL8-1 / SL8-6 safety/selector lever on “Safe”

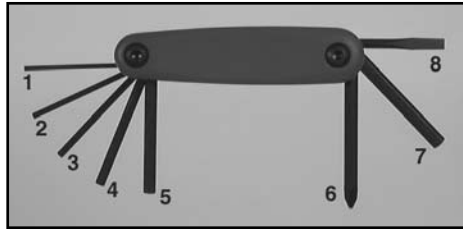
### **Major Cleaning (To be conducted after firing 1,000 rounds or if exposed to or submerged in water):**

1. Clean chamber and barrel extension with chamber brush caliber .223/5.56 mm
2. Take bolt group apart and clean its parts
3. Disassemble the gas system and clean the gas piston
4. Field strip the magazine and clean it
5. Apply a light coat of oil to all moving parts including the metal rails in the receiver
6. Reassemble the SL8-1 / SL8-6 and check the function
7. Set the SL8-1 / SL8-6 safety/selector lever on “Safe”

## **MAINTENANCE AND SERVICE**

### **HK SL8-1 / SL8-6 Combination Tool:**

All the necessary tools to adjust and field strip the SL8-1 / SL8-6 are part of the HK combination tool.



*Figure 44 HK Combination Tool*

1. Allen wrench 2 mm (iron sight, windage adjustment)
2. Allen wrench 2.5 mm (iron sight, elevation adjustment, Optical sight, adjustment)
3. Allen wrench, 3 mm
4. Allen wrench, 4 mm
5. Allen wrench, 5 mm (Allen head screws buttstock/receiver and buttplate adjustment)
6. Phillips screwdriver (cheekpiece adjustment)
7. Allen wrench, 6 mm
8. Screw driver, 5 mm

**NOTE: Failure to use these metric tools may cause damage to the SL8-1 & SL8-6 screws.**

## **Stoppages and Malfunctions**

In the event of stoppages on the SL8-1 or SL8-6, the weapon is to be considered loaded until the actual cause of the stoppage has been determined.

During the elimination of stoppages, safety precautions are to be taken into account.

If in the event of stoppages on the SL8-1 or SL8-6, the cartridge fired from the SL8-1 / SL8-6 is not ignited; the bolt assembly does not close completely; or the spent cartridge case is not ejected; then the following steps must be taken immediately

1. Put the SL8-1 / SL8-6 safety/selector lever on "Safe"
2. Remove the magazine
3. Unload the SL8-1 / SL8-6
4. Ensure that barrel, cartridge chamber and receiver are free of obstacles
5. Determine and eliminate the cause of the stoppage

<b>Stoppage, Fault</b>	<b>Cause</b>	<b>Remedy</b>
Cartridge is not ignited (dud round)	Ammunition fault (dud)	Recock SL8-1 & SL8-6
	Tip of firing pin damaged or broken	Contact HK for repair
	Hammer spring damaged or broken	Contact HK for repair
Bolt fails to open after being fired	Cartridge case stuck in chamber due to deformation or dirty chamber	Unload: retract bolt to eject cartridge case, clean if fouled. If required, contact HK for repair
	Gas system fouled or defective	Clean gas piston. If required, contact HK for repair

## ***TROUBLESHOOTING GUIDE***

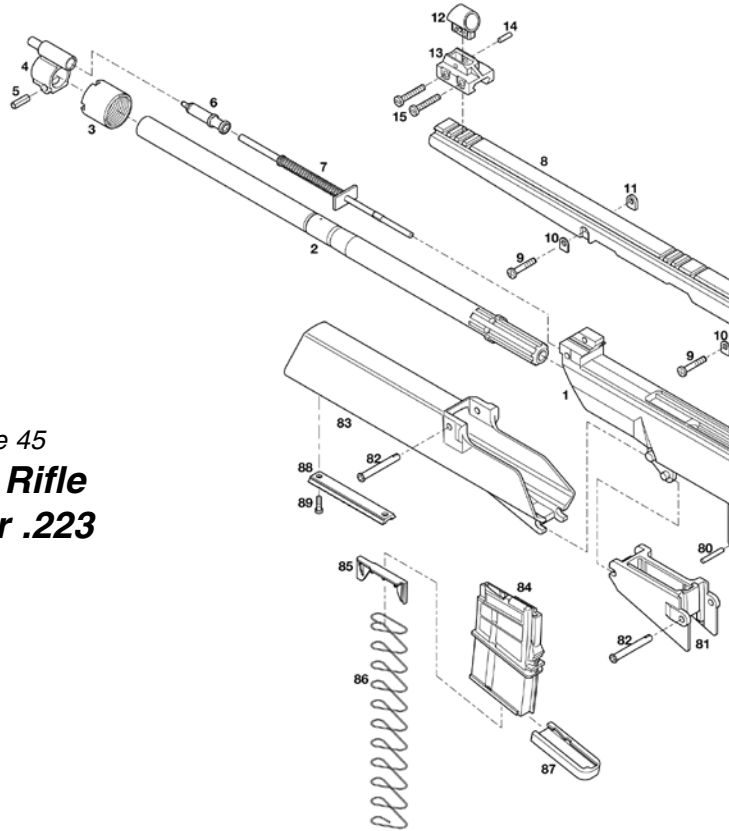
<b>Stoppage, Fault</b>	<b>Cause</b>	<b>Remedy</b>
Bolt does not close completely, cartridge not properly seated	Cartridge chamber dirty	Clean chamber
	Barrel extension dirty	Clean barrel extension
	Cartridge damaged	Replace cartridge
	Recoil spring worn	Contact HK for repair
	Incomplete cocking movement	Release cocking lever. Let it snap forward without riding it forward.
Cartridge case not extracted or ejected	Chamber dirty	Clean chamber
	Extractor or or extractor spring broken	Contact HK for repair
	Ejector or ejector spring damaged	Contact HK for repair
	Insufficient bolt recoil	Unload: Use cocking lever to retract bolt. Remove cartridge case. Check for smooth operation and check chamber for fouling. If required, clean chamber.
No cartridge fed by bolt	Magazine not properly inserted or engaged.	Insert magazine properly
	Magazine loose	Check magazine catch and lugs on magazine housing. If required, contact HK for repair.
	Follower spring worn	Replace or repair magazine
	Magazine lips damaged	Magazine housing damaged. If required contact HK for repair.
	Magazine well damaged	Return magazine well to HK for repair

## ***TROUBLESHOOTING GUIDE***

<b>Stoppage, Fault</b>	<b>Cause</b>	<b>Remedy</b>
Bolt does not stay open after last shot	Magazine follower spring worn	Replace magazine follower, or spring
SL8-1 & SL8-6 trigger cannot be pulled with hammer cocked	Sear broken or compression spring worn	Contact HK for repair
Magazine stuck in magazine well	Magazine damaged Magazine catch defective	Replace magazine Contact HK for repair

# PARTS LIST & EXPLODED DIAGRAM

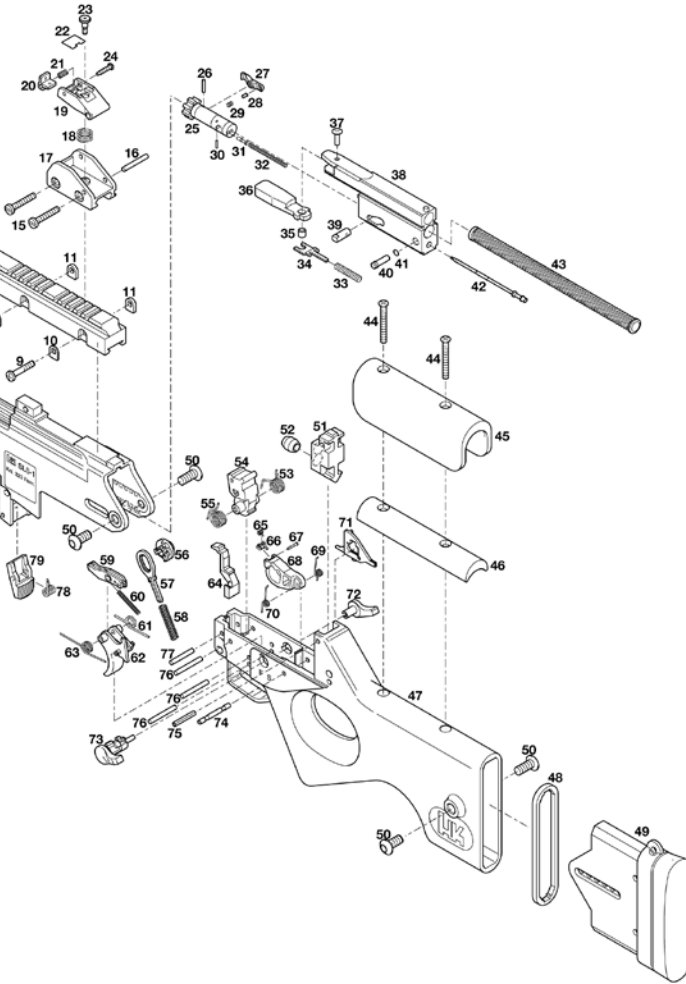
Figure 45  
**SL8-1 Rifle**  
**Caliber .223**



Item	Description	Part Number
	<i>Barrel, complete (2-5)</i>	<i>217906</i>
2	Barrel	217907
3	Barrel retaining nut	205378
4	Gas block	217919
5	Roll pin, gas block	927605
6	Piston, complete	205381
7	Piston rod, complete	205384
8	Mounting Rail	217947
9	Flat Headed Screw (3x)	986785
10	Washer (3x)	214112
11	Threaded Washer	214113
	<i>Front sight, complete (12-14)</i>	<i>217933</i>
12	Front sight	217796
13	Front sight base	217795
14	Roll pin, front sight	928747
15	Flat headed screw (4x)	988428
	<i>Rear sight, complete (16-24)</i>	<i>217925</i>
16	Roll pin, rear sight	987695
17	Rear sight guard	217992
18	Spring, elevation adjustment	217504
19	Rear sight housing	217991
20	Rear sight aperture	217997
21	Spring, windage adjustment	217518
22	Flat Spring	217515
23	Screw, elevation adjustment	217505
24	Screw, windage adjustment	217517
	<i>Bolt, complete (25-42)</i>	<i>219560</i>
	<i>Bolt head, complete (25-32)</i>	<i>219561</i>

Item	Description	Part Number
25	Bolt head	219562
26	Extractor axle	214644
27	Extractor	205406
28	Extractor spring	205407
29	Rubber pin for extractor	214662
30	Roll pin	928389
31	Ejector	205408
32	Spring, ejector	205411
	<i>Bolt head carrier, complete (33-38)</i>	<i>217909</i>
33	Spring, cocking handle	205393
34	Fork	205394
35	Bushing	205473
36	Cocking handle	205395
37	Rivet	205210
38	Bolt carrier	217910
39	Cam Pin	205390
	<i>Firing pin retainer, complete (40-41)</i>	<i>205412</i>
40	Firing pin retainer	205413
41	O-ring, firing pin retainer	983411
42	Firing pin	205391
43	Recoil spring complete	205445
	<i>Buttstock assembly, complete (44-76, 79)</i>	<i>219535</i>
44	Screw for check rest (2x)	988372
45	Cheekpiece	217948
46	Cheekpiece spacer	217916
48	Spacer, Buttplate	219537
50	Allen Screw, Buttstock (4)	217903
51	Back plate	219536

# PARTS LIST & EXPLODED DIAGRAM



Item	Description	Part Number	Item	Description	Part Number
52	Buffer	205452	70	Elbow spring, left	205201
53	Hammer spring, right	205428	72	Safety lever, right	205437
54	Hammer	217936	73	Safety lever, left	217945
55	Hammer spring, left	205429	74	Recessed axle	205202
56	Notched disk	217614	75	Clamping pin	988371
57	Index plate	205419	76	Axle (3x)	205469
58	Compression spring	205418	77	Actuator axle	205424
59	Sear complete	205439	78	Magazine release spring	205369
59a	Slide	219411	79	Magazine release	205368
60	Sear spring	217917	80	Axle	205469
61	Trigger spring	217918	82	Locking pin, complete (2x)	214125
62	Trigger	217934	83	Hand guard, complete	205364
63	Bolt catch spring	205466			
64	Bolt catch	214879			
	<i>Locking lever, complete</i>	<i>219094</i>			
65	Locking lever spring	214616	83	<i>Magazine, complete (10 rounds)</i>	<i>219472</i>
66	Locking lever	219095			
67	Bolt	214615	84	Magazine Housing	219473
68	Locking lever	214613	85	Follower	219474
69	Elbow spring, right	217946	86	Following spring	219475
				Magazine floorplate	219476
				HK Combination Tool	988496

## **SL8-1 & SL8-6 & SL8-6 SPECIFICATIONS**

---

Caliber	.223 Remington
Operating Principle	Gas operated, short stroke piston, rotary locking bolt
Mode of Fire	Semi-automatic
Feed Device	Single-stack polymer magazine, 10-round capacity
Sights	Adjustable iron sights. and detachable MIL-STD-1913 rail available for the attachment of accessory targeting devices
Rifling	6X lands & grooves, right hand twist, 1 turn in 7 inches
Length (overall)	38.58 inches (980 mm)
Barrel Length	20.80 inches (528 mm)
Sight Radius	17.65 inches (448 mm)
Width (overall)	2.36 inches (60 mm)
Height (overall)	9.84 inches (250 mm) with 10-rd magazine
Weights	
• Overall	8.60 pounds (3.9 kilograms with magazine)
• Magazine	2.47 oz. (70 grams) 10-round, empty

## SECTION 8 WARRANTY

### **WARRANTY REGISTRATION**

New HK firearms are covered by Heckler & Koch, Inc.'s Limited Lifetime Warranty. Warranty registration is now online. To register your new HK firearm, go to: <https://hk-usa.com/warranty/registration/>

If you do not have access to the Internet, contact Heckler & Koch, Inc. to obtain a warranty registration form:

HK Customer Service  
5675 Transport Boulevard  
Columbus, GA 31907  
Telephone: 706-701-5554.  
Email: [cs@heckler-koch-us.com](mailto:cs@heckler-koch-us.com)

### **HECKLER & KOCH, INC. LIMITED LIFETIME WARRANTY**

All new Heckler & Koch, Inc. firearms purchased after January 1, 1998, are warranted to the original retail purchaser only for the lifetime of the said original retail purchaser. In the event that this original retail purchaser, at the time of the original purchase, shall donate this firearm to another person, the donee name must be submitted during the online warranty registration. Heckler & Koch, Inc. does not guarantee or warrant that any, all, or some donations or gifts are valid and compliant with all applicable laws, regulations, and ordinances. Heckler & Koch, Inc. is not responsible or liable in any way for a donation or gift that does not comply with applicable laws, regulations, and ordinances. It is the responsibility of the original retail purchaser and the donee or recipient to ensure that any such transfer complies with all applicable laws, regulations, and ordinances. Upon completion of the online warranty registration indicating the name of the said donee, this warranty shall be extended to the lifetime of the said donee. This warranty applies only if the firearm was imported into the United States and distributed by Heckler & Koch, Inc. to an authorized dealer.

### **What Will We Do?**

Heckler & Koch Inc. will, at its option, repair or replace without charge any HK firearm that fails due to a defect in materials or workmanship. Parts and labor are included. Repairs are warranted for the duration of the warranty. If Heckler & Koch, Inc. replaces a firearm under this warranty; you will receive a new warranty. Heckler & Koch, Inc. will return your firearm to you shipping pre-paid.

### **How to Obtain Service:**

Contact Heckler & Koch, Inc. via phone at 706-701-5554 or email at [cs@heckler-koch-us.com](mailto:cs@heckler-koch-us.com) for a Return Authorization Number before sending your firearm freight prepaid to Heckler & Koch, Inc. at the address listed below. No C.O.D. shipments will be accepted.

Only the existing Heckler & Koch, Inc. Service Center or any other authorized Heckler & Koch, Inc. Service Center that may be established by Heckler & Koch, Inc. shall be authorized to make warranty repairs.

Return the complete, unloaded firearm with a detailed description of the problem using Heckler & Koch, Inc.'s Return Form.

**DO NOT send any live ammunition with the firearm. If you must send ammunition to us for proof purposes, be sure that it is sent separately from the firearm.**

We strongly recommend that you complete the online warranty registration at <https://hk-usa.com/warranty/registration/> to establish eligibility for warranty service. If you do not return an acknowledgment of online warranty registration to Heckler & Koch, Inc., you are required to provide adequate proof of the date that you purchased your new HK firearm at the time you send your firearm to Heckler & Koch, Inc. for warranty service.

In the event that this firearm was given as a gift at the time of original purchase, the online warranty registration with the name of the donee must be provided to Heckler & Koch Inc., in order for the warranty to become effective.

Note: Non-warranty servicing must follow the same shipping procedures as stated above. HK firearms with a valid Return Authorization Number should be shipped to the following address in accordance with these instructions:

HKI

Attn: Service Department/RA# \_\_\_\_\_  
5675 Transport Blvd.  
Columbus, GA 31907

Any information gathered in connection with a Heckler & Koch Inc. lifetime limited warranty shall be used for that purpose and may be used for other legitimate business purposes of Heckler & Koch Inc. For further information, please review Heckler & Koch, Inc.'s Privacy Policy, located at <https://hk-usa.com/cookie-policy-us/>

### **What Is Not Covered?**

This warranty does not cover defects or damage caused by: (1) unreasonable use; (2) failure to provide proper care or maintenance; (3) failure to comply with instructions in the operator's manual including improper installation of original Heckler & Koch Inc. parts by the owner or his agent; (4) normal wear and tear for the degree of use; (5) rust or corrosion; (6) obstructions in the barrels; (7) excessive use; and/or (8) external and internal cosmetic finishes.

Heckler & Koch, Inc. reserves the right to determine what constitutes the unreasonable or excessive use of the firearm. All wooden parts and all accessories are excluded from warranty coverage.

This warranty does not cover any claims made by the second or subsequent owner of an HK firearm as stated above.

**NOTICE** Any unauthorized alteration or modification of the firearm or use of parts or components not originally made by Heckler & Koch, Inc. may void this warranty. Heckler & Koch, Inc. is not be responsible for any claims involving this firearm that result from the use of faulty, nonstandard, remanufactured, or reloaded ammunition or ammunition not manufactured to NATO, CIP, and/or SAMMI specifications.

Under no circumstances shall Heckler & Koch, Inc. be responsible or liable for incidental or consequential damages with respect to loss of use, loss of business or profits, other economic loss or injury to property, whether as a result of breach of express or implied warranty, negligence or otherwise. This Limited Lifetime Warranty applies only to retail purchases by individuals through an authorized Heckler & Koch, Inc. dealer.

**Residents of CALIFORNIA, CONNECTICUT, DISTRICT OF COLUMBIA, HAWAII, MARYLAND, MASSACHUSETTS, MICHIGAN, NEW JERSEY, NEW YORK, AND U.S. TERRITORIES.**

Any work involving replacement of the receiver of a firearm requires that the firearm be returned to a licensed firearms dealer. A current, signed copy of the dealer's FFL will be required. Please provide contact information for the chosen dealer, if applicable.

**NOTICE** Customers in restrictive capacity states: **DO NOT ship high capacity magazines to Heckler & Koch Inc. They cannot be returned.**

## **Exclusions**

This lifetime warranty explicitly excludes firearms purchased by the United States military, government institutions or agencies of the United States or any of its constituent states and territories, law enforcement agencies of the United States or any of its constituent states and territories, and/or security organizations located within the United States or any of its constituent states and territories. Firearms purchased by these entities and organizations for duty issue to their personnel and/or employees are covered by a one-year limited warranty against material defects and workmanship or as agreed upon in a valid contract.

This lifetime warranty also excludes rimfire .22L R firearms, and all suppressors, which are covered by a one-year warranty.

Some states do not allow the exclusion or limitation of incidental or consequential damages, so the above limitations or exclusions may not apply to you. This warranty gives you specific legal rights, and you may also have other rights, which vary from state to state. This limited warranty is the only express warranty by Heckler & Koch Inc.

Heckler & Koch Inc. does not authorize any dealer or any other person to vary the terms of this warranty or make any other express warranties.

## **Heckler & Koch, Inc. Lifetime Barrel Guarantee**

Heckler & Koch, Inc. guarantees the serviceability of the bore of the barrels of all MR A4 Series rifles and pistols for the lifetime of the original consumer purchaser for individual use. This guarantee is based on barrels meeting standards on accuracy, velocity, and useability across the entire life of the A4 system. If at any time an A4 barrel fails to meet these standards, Heckler & Koch, Inc. will replace the barrel.



## **Where to Get Further Help**

If you have questions concerning this warranty, please contact Heckler & Koch, Inc.'s Customer Service Department at:  
5675 Transport Blvd.  
Columbus, GA 31907  
Telephone: 706-701-5554  
Email: [cs@heckler-koch-us.com](mailto:cs@heckler-koch-us.com)







**HECKLER & KOCH**

*Remember, firearms safety begins with you. Read and follow all safety information in the operators manual. Store all firearms in a safe and secure location. Keep firearms away from children. Always be a safe shooter.*

Heckler & Koch  
5675 Transport Blvd.  
Columbus, GA 31907  
United States of America  
Tel. (706) 568-1906  
[www.HK-usa.com](http://www.HK-usa.com)

Heckler & Koch GmbH  
D-78722 Oberndorf/Neckar  
Postfach 1329  
Germany  
Tel. 011-49-7423/79-0  
Fax 011-49-7423/2280  
[www.heckler-koch.de](http://www.heckler-koch.de)